



FLO-CORP.com

FLOSENTRY II™ MFFS2 Single Alarm System OPERATING INSTRUCTIONS



Table Of Contents

Introduction	3
Basic Operation	3
Safety Precautions	3
Specifications	4
Guide to Controls	5
Alarm Point Adjustment	6
Installation	7-8
Application Examples	8-9
Maintenance	9
Ordering Information	10
Return & Warranty Policy	11

About This Manual:

PLEASE READ THE ENTIRE MANUAL AND SPECIFICATIONS PRIOR TO INSTALLING OR USING THIS PRODUCT.

This manual includes information on the FloSentry II Single Alarm System and how it operates with Flow Line Options' MEMFlo meter. It is important to review all safety precautions and operating limits. The FloSentry II Systems are designed for industrial environments, and by taking a few moments to review the instructions you will be assured long, trouble-free service.

Introduction

Compatible with most MEMFlo meters, FloSentry II is a great choice for a variety of single alarm applications. FloSentry II provides a high or low level switch with a single sensor input. This alarm system can be added to most flow devices to provide intelligent process automation as well as, safety capabilities. The optional strobe light brings immediate attention to process conditions. Typical applications include process gas flows, biodiesel fuel manufacturing, chemical processing, biomedical, coolant system, water and wastewater treatment facilities.

Basic Operation

The MEMFlo Flo-Sentry systems consist of two main parts - the MEMFlo flow meter and the FloSentry alarm. The MEMFlo flow meter comes with a magnet on the flow meter float. The FloSentry alarm comes with a hall-effect sensor mounted in the switch enclosure that will detect when the magnet on the flow meter float passes by its "field". The sensor is completely adjustable simply by moving the sensor clip up or down depending on your switch point.

CAUTION: WHEN REMOVING THE SENSOR HOUSING MAKE SURE ALL ELECTRICAL CIRCUITS TO THE FLOSENTRY ARE TURNED OFF AND NO VOLTAGE IS APPLIED TO THE CIRCUIT. RISK OF ELECTRICAL SHOCK, DANGER OF DEATH MAY OCCUR IF THIS CIRCUIT IS LEFT ON.

Safety Precautions

Flow Line Options manufactures several devices for a variety of flow and level applications. It is the user's responsibility to select a unit that is appropriate for the application, install it properly, perform tests and maintain all components.

Electrical Shock Hazard

It is possible to contact components on the controller that carry high voltage, causing serious injury or death. All power to the controller and the relay circuit(s) it controls should be turned OFF prior to working on the controller. If it is necessary to make adjustments during powered operation, use extreme caution and use only insulated tools. Making adjustments to powered controllers is not recommended. Wiring should be performed by qualified personnel in accordance with all applicable national, state and local electrical codes.

Flammable or Explosive Applications

Sensor mount controllers should not be used with explosive or flammable liquids, which require an intrinsically safe rating. If you are unsure of the suitability of a controller for your installation, consult your Flow Line Options representative for further information.

Install In a Dry Location:

The controller housing is liquid-resistant and is made of Polypropylene (PP). When installed properly, the controller is not designed to be immersed. It should be mounted in such a way that it does not normally come into contact with fluid. Refer to an industry reference to ensure that compounds that may splash onto the controller housing will not damage it. Such damage is not covered by the warranty.

Relay Contact Rating:

The relay is rated for a 10 amp resistive load. Many loads (such as a motor during start-up or incandescent lights) are reactive and may have an inrush current characteristic that may be 10 to 20 times their steady-

Specifications

Service	Compatible gasses or liquids
Supply Voltage	120/240 VAC @ 50-60 Hz
Consumption	0.25 A
Sensor Inputs	(1) two-wire level switch
Sensor Supply	13.5 VDC @ 27 mA
Contact Type	(1) SPDT relay
Contact Rating	250 VAC @ 16A
Contact Delay	0-60 seconds
LED Indication	Sensor, power and relay status
Electronics Temp.	F: -40° to 158° C: -40° to 70°
Enclosure Rating	NEMA 4 (IP65)
Controller Material	PP, UL94VO
Switch Material	Anodized aluminum
Controller Rotation	300° swivel base
Conduit Entrance	100_: 3/4" NPT 105_: 3/4" Rp
Classification	General purpose
Certificate	CSA: LR 79326
CE Compliance	EN 61326 EMC EN 61010-1 safety
Strobe Light (Optional)	
Strobe Type	Xenon tube
Strobe Flash	1 per second
Lens Material	Polycarbonate

Note: Please Consult Factory for Special Requirements

Dimensions

- * Size 12 Meters
- * Size 06 Meters

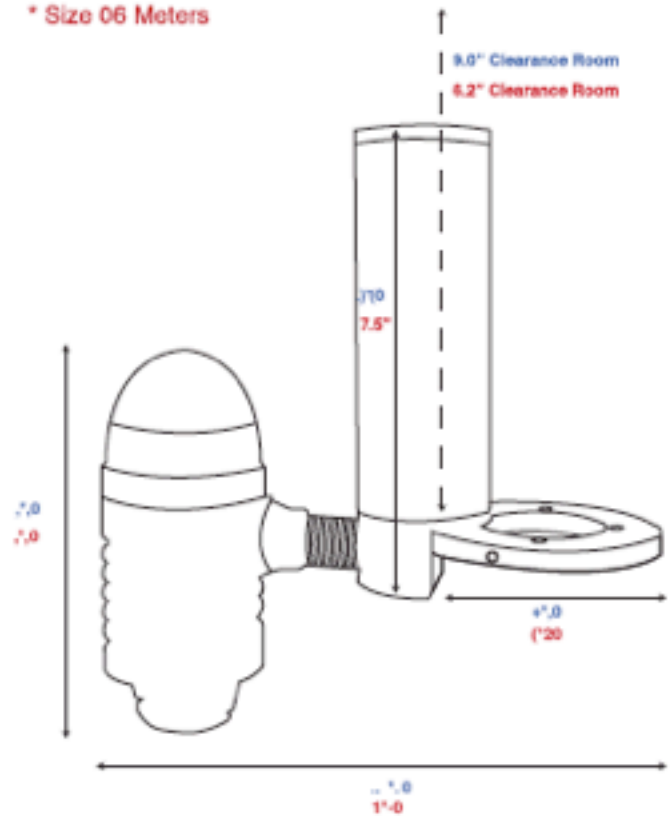

Internal Controller Logic

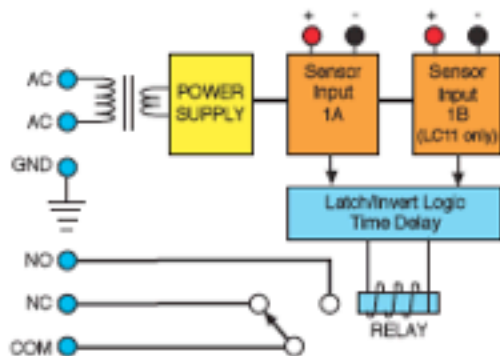

Controller Faceplate

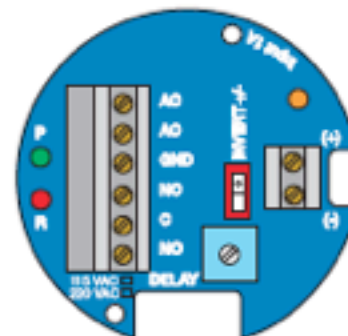

Specifications

Service	Compatible gasses or liquids
Supply Voltage	120/240 VAC @ 50-60 Hz
Consumption	0.25 A
Sensor Inputs	(1) two-wire level switch
Sensor Supply	13.5 VDC @ 27 mA
Contact Type	(1) SPDT relay
Contact Rating	250 VAC @ 16A
Contact Delay	0-60 seconds
LED Indication	Sensor, power and relay status
Electronics Temp.	F: -40° to 158° C: -40° to 70°
Enclosure Rating	NEMA 4 (IP65)
Controller Material	PP, UL94V0
Switch Material	Anodized aluminum
Controller Rotation	300° swivel base
Conduit Entrance	100 : 3/4" NPT 105 : 3/4" Rp
Classification	General purpose
Certificate	CSA: LR 79326
CE Compliance	EN 61326 EMC EN 61010-1 safety
Strobe Light (Optional)	
Strobe Type	Xenon tube
Strobe Flash	1 per second
Lens Material	Polycarbonate

Note: Please Consult Factory for Special Requirements

Dimensions

- * Size 12 Meters
- * Size 06 Meters

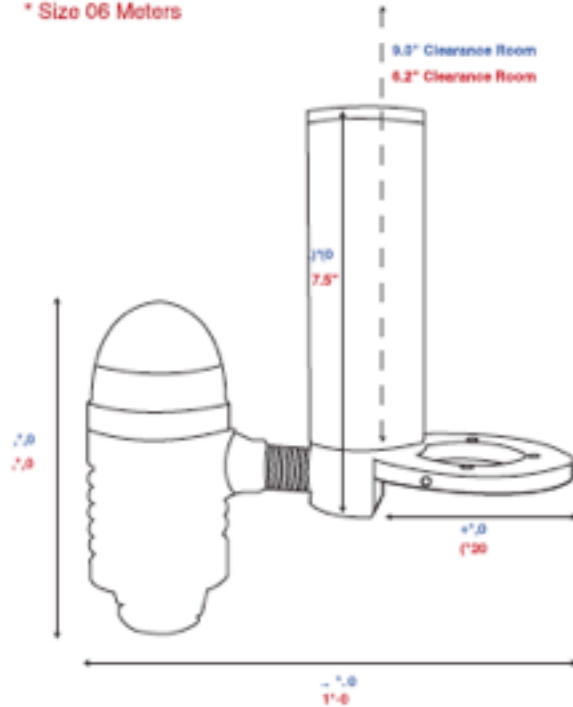

Internal Controller Logic

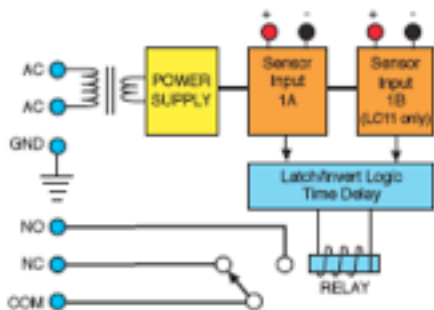

Controller Faceplate

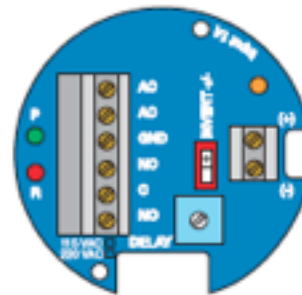

Guide To Controls

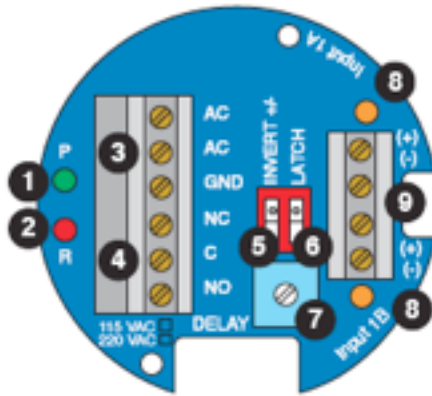

1. **Power indicator:** This green LED lights when AC power is ON.
2. **Relay indicator:** This red LED will light whenever the controller energizes the relay, in response to the proper condition at the sensor input(s) and after the time delay.
3. **AC Power terminals:** Connection of 120 VAC power to the controller. The setting may be changed to 240 VAC if desired. This requires changing internal jumpers; this is covered in the Installation section of the manual. Polarity (neutral and hot) does not matter.
4. **Relay terminals (NC, C, NO):** Connect the device you wish to control (pump, alarm etc.) to these terminals: supply to the COM terminal, and the device to the NO or NC terminal as required. The switched device should be a non-inductive load of not more than 10 amps; for reactive loads the current must be derated or protection circuits used. When the red LED is ON and the relay is in the energized state, the NO terminal will be closed and the NC terminal will be open.
5. **Invert switch:** This DIP switch reverses the logic of the relay control in response to the sensor(s): conditions that used to energize the relay will make it turn off and vice versa.
6. **Time Delay:** After the input(s) change(s) state, this control sets a delay from 0.15 to 60 seconds before the relay will respond.
7. **Input 1A and 1B indicator:** These amber LEDs will light immediately whenever the appropriate sensor attached to the terminals detects liquid, and will turn off when it is dry.
8. **Input terminals:** The sensor is pre-wired to the terminals. Note the polarity: (+) is a 13.5 VDC, 27 mA power supply (connected to the red wire of a Flow Line Options sensor), and (-) is the return path from the sensor (connected to the black wire of a Flow Line Options sensor). If polarity is reversed, the sensors will not work.

Alarm Point Adjustment

Alarm points may be adjusted without removing the flow meter from the pipeline and without interrupting flow. However, it may be easier to set initial alarm points prior to meter installation. Flow Line Options Corp. can also preset alarm points for an additional charge.

CAUTION: ALWAYS SHUT OFF AND DISCONNECT POWER TO THE FLOENTRY BEFORE OPENING THE SWITCH ENCLOSURE AND MAKING ADJUSTMENTS!

To access the hall-effect switch, remove the screw at the top of the enclosure. The cover may now be lifted straight up, exposing the switches. On explosion-proof enclosures, remove the bolts and front cover to access switches.

The switch is held by a spring clip on a carrier block locked into position on the vertical post by a set screw. Loosening this set screw allows vertical post by a set screw. Loosening this set screw allows vertical adjustment of the switch.

The vertical adjustment is normally the only change required to alter switch points. If necessary or desired, the switch can be repositioned within the spring clip, either closer to or farther away from the float magnet.

Installation

VAC Power Input Wiring:

Observe the labeling on the controller. **Note:** Polarity does not matter with the AC input terminal.

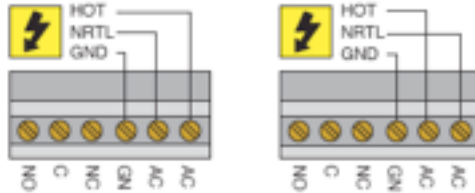

Relay Input Wiring

The relay is a single pole, double throw type rated at 250 Volts AC, 10 Amps, 1/4 Hp. The two terminal NO and NC (normally open and normally closed) will be used in different applications. Remember that the "normal" state is when the relay coil is de-energized and the Red relay LED is Off / de-energized.

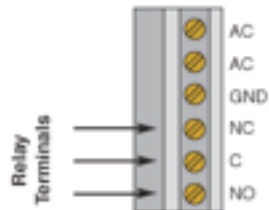

Strobe Alert Output

With the Strobe Alert wired NC, it can be used as a high or low level alarm, depending on the setting for the invert switch. Strobe can also be wired NO.

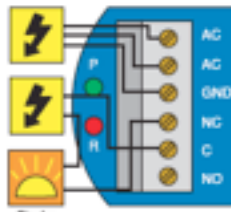

Changing from 120 to 240 VAC

1. Remove the two screws from the top of the printed circuit board (PCB) and gently slide the PCB from the housing. Use caution when removing the PCB.
2. Located jumpers JWA, JWB and JWC on the PCB.
3. To change to 240 VAC, remove jumpers from JWB and JWC and place a single jumper across JWA. To change to 120 VAC, remove jumper JWA and place jumpers across JWB and JWC.
4. Gently return PCB into housing and replace the two screws.

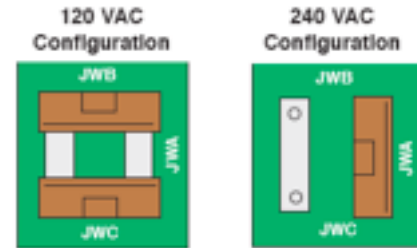

Flow Meter Installation

Please reference the 'Installation' section of the flow meter instruction manual, paying particular attention to the safety precautions.

Application Examples

Low Flow Alarm

The goal is to make sure that the liquid flow does not fall below a certain point. If it does, an alarm is supposed to sound, alerting the operator of a low flow condition.

If power is accidentally cut to the controller, the sensor's ability to notify the operator of a low flow condition could be lost. The system must alert the operator not only to low flow, but to controller power loss.

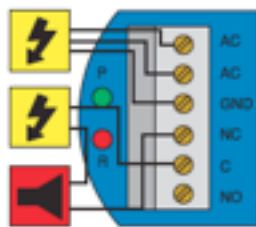

To do this, connect the hot lead of the alarm to the NC side of the relay terminal of the controller. If power is lost, the relay will be de-energized, and the alarm will sound (if there is still power to the alarm circuit itself). The alarm circuit should have a non-interruptible power supply or some other indicator or backup alarm to warn of a power failure in the alarm circuit.

In this application, the normal status if the sensor at the bottom of the tank will be wet, and the relay will be energized holding the alarm circuit open. Both the relay LED and the Input LED will be on simultaneously,

so for this application, Invert should be set to the Off position.

High Flow Alarm

In the same manor, this system can be used to sound an alarm when media reaches a high flow, with just a change in the location of the sensor and the setting of the Invert switch.

The alarm is still connected to the NC side of the relay to allow for a power failure alarm.

Ordering Information

FLO-CORP MODEL NUMBER BUILDER

For Assistance Call 877.FLO.LINE

Use the diagram below, working from left to right to construct your Flo-Corp Model Number.
Simply match the category number to the corresponding box number.

Example: MFFS2-02

FloSentry II, 3/4" NPT Conduit Entrance, Controller with Strobe Alert Configuration

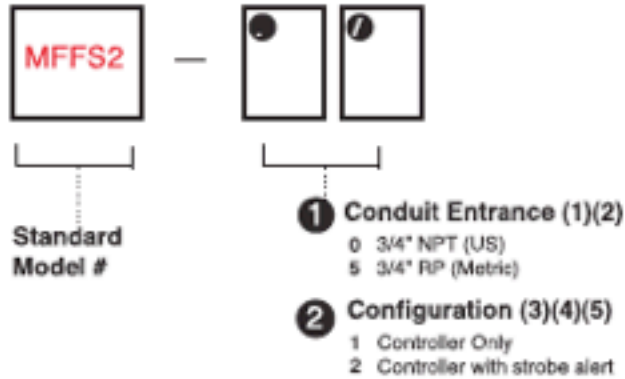

Ordering Notes

- 1) Please note that this device can ONLY be used in addition to a MEMFlo Flow Meter.
- 2) If ordering this device for an existing MEMFlo meter, please contact factory with flow range.
- 3) To factory configure for 240 VAC, place an E at the end of the P/N: (ie: MFFS2-02-E).
- 4) To order the CE configuration, place CE at the end of the P/N: (ie: MFFS2-02-CE).
- 5) For a liquid tight cable connection, order the LM90-1001 connector.

Specifications are subject to change without notice.

Photo shown **without**
MEMFlo Flow Meter



Photo shown **with**
MEMFlo Flow Meter



Return Policy

Flow Line Options Corporation warrants this product against defects in material or workmanship for the specified period under "Specifications" from the date of shipment from the factory. Flow Line Options Corporation liability under this limited warranty shall not exceed the purchase value, repair, or replacement of the defective unit.

Warranty Policy

Flow Line Options Corp. warrants to the original purchaser of its products that such products will be free from defects in material and workmanship under normal use and service for a period which is of eighteen months from the date of purchase. This warranty covers only those components of the products which are non-moving and not subject to normal wear. Moreover, products which are modified or altered. Flow Line Options obligation under this warranty is solely and exclusively limited to the repair or replacement, at Flow Line Options decision, of the products (or components thereof) which Flow Line Options' examination proves to its satisfaction to be defective. FLOW LINE OPTIONS SHALL HAVE NO OBLIGATION FOR CONSEQUENTIAL DAMAGES TO PERSONAL OR REAL PROPERTY, OR FOR INJURY TO ANY PERSON. This warranty does not apply to products which have been subject to electrical or chemical damage due to improper use, accident, negligence, abuse or misuse. Abuse shall be assumed when indicated by electrical damage to relays, reed switches or other components. The warranty does not apply to products which are damaged during shipment back to Flow Line Options' factory or designated service center or are returned without the original casing on the products. Moreover, this warranty becomes immediately null and void if anyone other than service personnel authorized by Flow Line Options attempts to repair the defective products. Products which are thought to be defective must be shipped prepaid and insured to Flow Line Options' factory or a designated service center (the identity and address of which will be provided upon request) within 30 days of the discovery of the defect. Such defective products must be accompanied by proof of the date of purchase. Flow Line Options further reserves the right to unilaterally waive this warranty and to dispose of any product returned to Flow Line Options where: a. There is evidence of a potentially hazardous material present with product. b. The product has remained unclaimed at Flow Line Options for longer than 30 days after dutifully requesting disposition of the product. THERE ARE NO WARRANTIES WHICH EXTEND BEYOND THE DESCRIPTION ON THE FACE OF THIS WARRANTY. This warranty and the obligations and liabilities of Flow Line Options under it are exclusive and instead of, and the original purchaser hereby waives, all other remedies, warranties, guarantees or liabilities, express or implied. EXCLUDED FROM THIS WARRANTY IS THE IMPLIED WARRANTY OF FITNESS OF THE PRODUCTS FOR A PARTICULAR PURPOSE OR USE AND THE IMPLIED WARRANTY OF MERCHANT ABILITY OF THE PRODUCTS. This warranty may not be extended, altered or varied except by a written instrument signed by a duly-authorized officer of Flow Line Options Corp.

Disclaimer

The information contained in this document is subject to change without notice. Flow Line Options Corporation makes no representations or warranties with respect to the contents hereof and specifically disclaims any implied warranties of merchantability or fitness for a particular purpose.

All trademarks mentioned in this document are the property of Flow Line Options Corporation.

