



FLO-CORP.com

NITROFLO™ CFNF

Compact Air Flow Switch

OPERATING INSTRUCTIONS



Table of Contents

Installation & Adjustment Instructions.....	1
Switching Characteristics.....	1
Monitoring.....	3
Dimensions.....	4

Other products we provide...

- Direct Reading Flow Meters
- Ultrasonic Flow Meters
- Turbine Flow Meters
- Vortex Flow Meters
- Mass Flow Meters
- Positive Displacement Flow Meters
- Totalizing Water Meters
- New Combined Sewer Overflow
- Calorimetric Flow Meters
- Flow Computers
- Flumes & Weirs
- Flow Calibration & Testing Services
- Ultrasonic Level Sensors
- Echopod Small Tank Level Control
- EchoSafe Explosion Proof Transmitters
- Differential Pressure Level Transmitters
- Liquid Flow Switches
- Gas Flow Switches
- More On www.flowlineoptions.com



Installation and Adjustment Instructions

Please read carefully! No liability can be accepted for damage caused by improper use of this product.

Installation

With supplied mounting flange (optional PG 21) or union nut (Type CFNF-S)

Installation Depth

Dependent on duct diameter, min. 0.6 in (15 mm)
 Metal PG21 fittings are modified by the manufacturer.
 Modification is indicated by a 1" on the fitting's hexagon nut.

Flow Direction

Position the probes lengthwise parallel to flow

Type CFNF-U

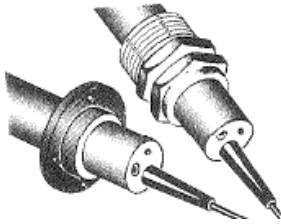

mounting flange

Type CFNF-S

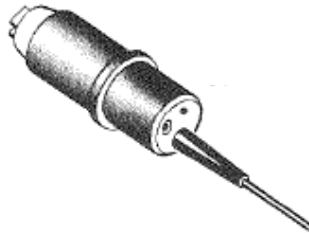

stainless steel casing

Flow Direction



Electrical Connection

Ensure that the unit is connected in accordance with the appropriate electrical connection diagram

Attn: This unit is not short circuit protected!

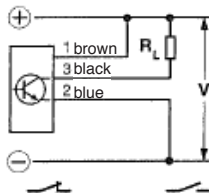

DC/NPN ----.00 ----.01

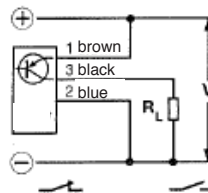

DC/PNP ----.02 ----.03

Switching Characteristics

Starting Override Time

The thermal time delay applies to a cold unit, at factory set-point approx. 10 to 15 seconds.

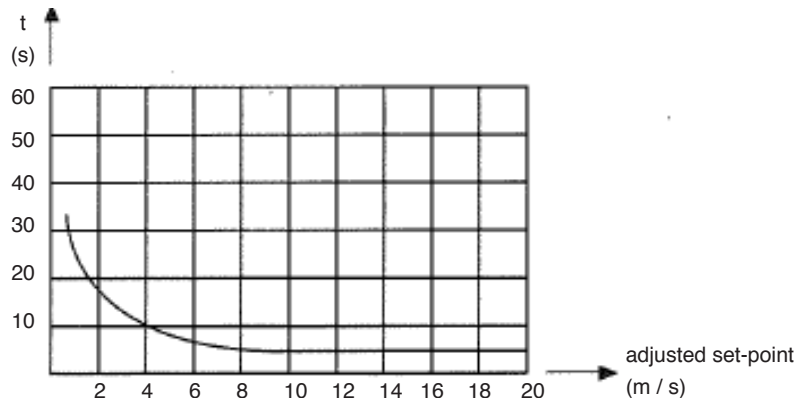

Switching Delay

The time delay of the unit is defined by the rate of change of flow speed relative to the set-point. This time delay is not constant, the faster the change, the shorter the time delay. Depending upon adjustment, it varies from 2 seconds to more than 30 seconds.

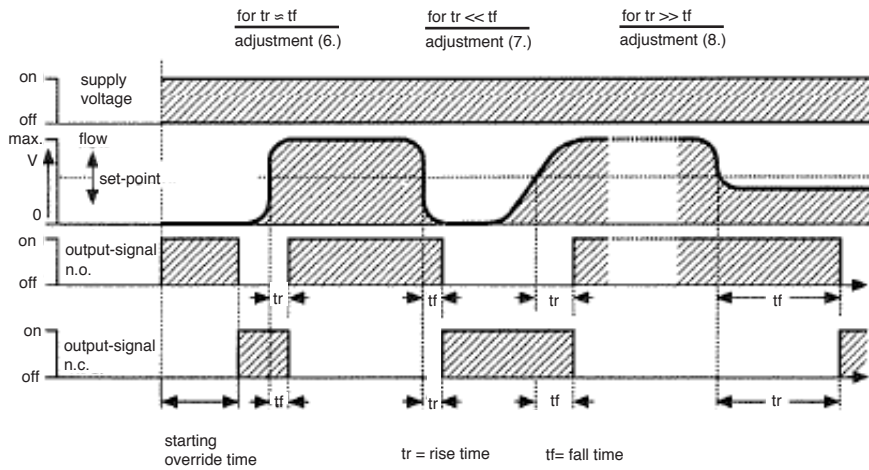

LED-Function

Units with normally open switching function:

- LED "OFF" - no flow = output "OFF"
- LED "ON" flow = output "ON"

Units with normally closed switching function:

- LED "OFF" - no flow = output "ON"
- LED "ON" flow = output "OFF"

Set-point Adjustment

For general applications these units are factory set at an air flow rate of 9.8 fps (3 mps) and are therefore ready to use without any further adjustment.

Changing Set-point

Stable operating condition reached 5 minutes after electrical connection

Decrease sensitivity (clockwise)

Increase sensitivity (counter-clockwise)

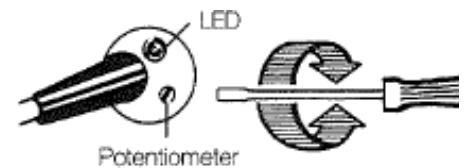

The following instructions refer to units with normally open output!

With no air flow turn adjustment pot. until LED "ON" (This position sets switch = point to zero flow). Slowly turn adjustment pot. until LED "OFF" = most sensitive setting. Further adjustment, max. 18 turns results in least sensitivity.



Attention: 18 turn potentiometer without mechanical end point.

Monitoring Air Flow Failure

After 5 minutes with no air flow, turn pot. until LED "ON"



Turn on normal air flow, wait 3 minutes, adjust pot. (counting the turns) until LED "OFF"

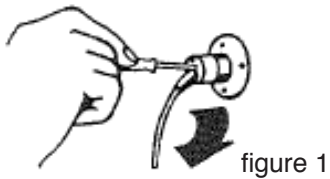

Turn back half the number of turns as figure 1 = optimum setting, $tr \approx tf$

Monitoring Lower Flow Limit

Reduce flow to the min. rate at which a signal is required.
After 5 minutes slowly turn pot until LED "OFF"

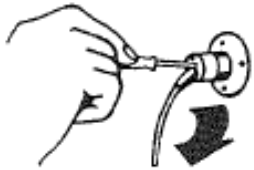

Increase flow rate to normal rate, wait 3 minutes, if LED "ON" setting is correct
If LED says "OFF" the flow rate difference is too small. In this case turn slowly until LED "ON"



Monitoring Upper Flow Limit

Increase flow to rate at which a signal is required
Turn pot. until LED "OFF"
Wait 5 minutes turn ot slowly until LED "ON"

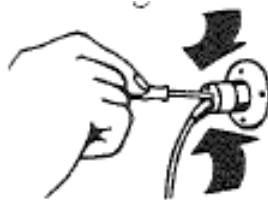

Decrease flow to normal rate. Wait 3 minutes, if LED "OFF" setting is correct
If LED stays "ON" the flow rate difference is too small. In this case turn pot. until LED "OFF"



Electrical Data	
Voltage Supply	24 VDC \pm 30% / -32.5%
Switching Current	Max. 200 mA
Power Consumption	approx. 800 mW to 1.3 W 9 at max. flow)
Starting override time (set-point dependency)	approx. 30 s at 0.5 m/s to approx.5 s at 20 m/s
Electrical output at no flow	3202.00 NPN current bearing (n.c.) 3202.02 PNP current bearing (n.c.) 3202. 01 NPN absense of current (n.o.) 3202.03 absense of current (n.o.)
Display	LED, at flow condition: ON

Mechanical Data	
Material	Sensor probe: Ceramic with overglaze Housing: Ultradur (PBTP)
Medium Temperature Range	-20° C to +70° C (-4° F to +160° F)
Ambient Temperature	-20° C to +70° C (-4° F to \pm 160° F)
Electrical Connection	2 m moulded oilflex cable / 3 x 0.5 mm ²
Protection Standard	IP64
Mass	130 g

Dimensions

Housing	X	Y
Short	2.6"	3.1" (79 mm)
Long	3"	3.5" (89 mm)

CFNF-U_: Ultradur (PBTP) Housing

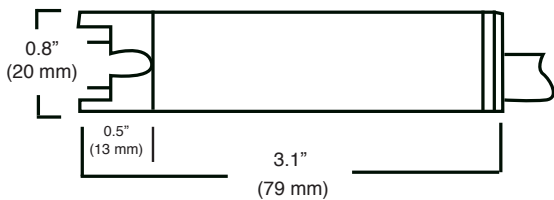

Weight: 130 grams
(0.3 lbs)

CFNF-S_: Stainless Steel Housing
(installation with union nut)

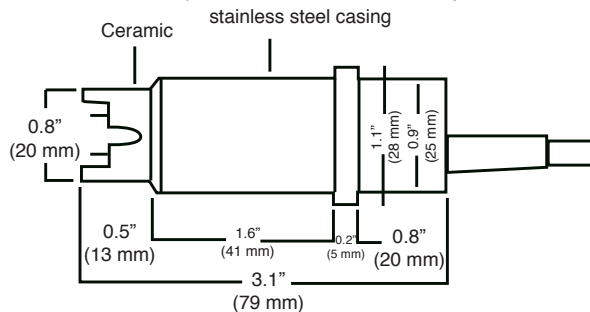

Weight: 200 grams (0.41 lbs) w/o union nut
Union Nut: 127.3 grams (0.3 lbs)

Mounting Flange

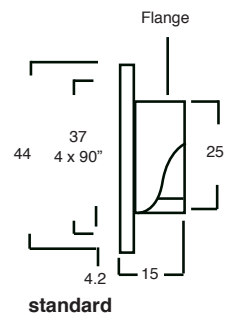

standard